

Radial piston pumps type PFR

fixed displacement

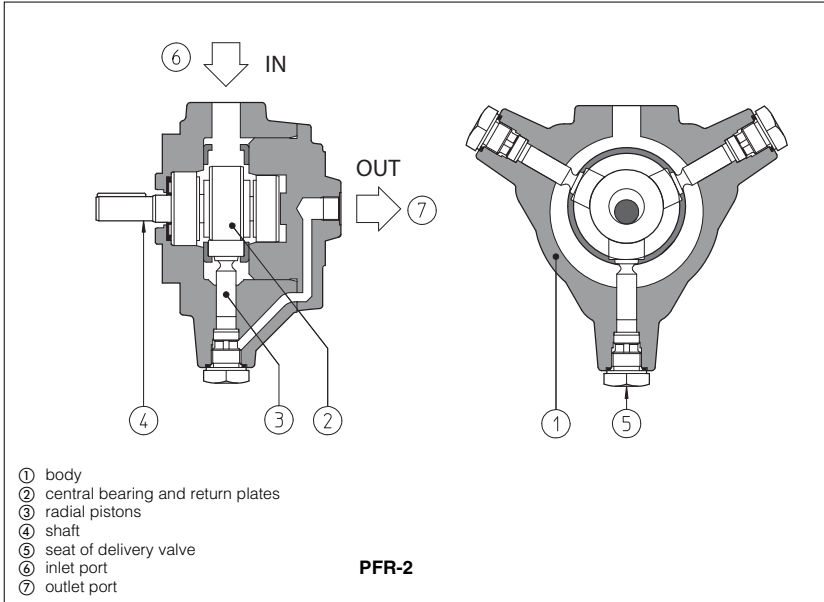

PFR are fixed displacement radial piston pumps with positive drive construction of the pistons ③ (without return spring) for high performance and low noise level.

Suitable for hydraulic oils according to DIN 51524... 535 or synthetic fluids having similar lubricating characteristics.

These pumps are available as single or with through-shaft configuration in order to be coupled to PFE vane pumps, see table A190.

Wide range of displacements from 1,7 up to 25,4 cm³/rev.
Max pressure up to 350/500 bar.

1 MODEL CODE

PFR	XA	- 3	08	**	/*
Fixed displacement radial piston pump				Synthetic fluids: WG = water-glycol PE = phosphate ester	Series number
Additional suffix for pumps provided to be coupled with vane pump type PFE (tab. A005), see section 2			Displacement [cm ³ /rev], see section 2 for PFR-2: 02, 03, 06 for PFR-3: 08, 11, 15 for PFR-5: 18, 22, 25		
Only for PFR-3 and PFR-5: XA = provided (throughgoing shaft, flange and joint) to be coupled with PFE-31 XB = provided (throughgoing shaft, flange and joint) to be coupled with PFE-41 XC = provided (throughgoing shaft, flange and joint) to be coupled with PFE-51			Conventional size, see section 2: 2, 3, 5		
See table A190 for codes of complete multiple pumps: PFR +PFE = PFRX*E					

2 OPERATING CHARACTERISTICS at 1450 rpm (based on mineral oil ISO VG 46 at 50°C)

Model	Displacement cm ³ /rev	Max pressure bar	Speed range rpm	150 bar (3) l/min	(3) kW	250 bar (3) l/min	(3) kW	350 bar (3) l/min	(3) kW	500 bar (3) l/min	(3) kW
PFR-202	1,7	500 (1)	600-1800 (2)	2,4	0,7	2,4	1,1	2,4	1,6	2,4	2,1
PFR-203	3,5			5,0	1,4	5,0	2,2	4,9	3,0	4,9	4,2
PFR 206	5,8	350 (1)		8,3	2,4	8,3	3,7	8,2	4,9	-	-
PFR-308	8,2			11,8	3,2	11,5	5,6	11,5	7,5	-	-
PFR-311	11,4			16,5	4,5	16,4	7,8	16,2	10	-	-
PFR-315	14,7			21,3	6,3	21,3	10,0	20,9	12,5	-	-
PFR-518	18,1			26	7,7	25,8	12,3	25,6	15,2	-	-
PFR-522	21,8			31,5	9,5	31,2	14,9	31	18,4	-	-
PFR-525	25,4			36,5	11	36	17,3	35,5	21,6	-	-

(1) Max pressure is 250 bar for /PE versions; max pressure is 175 bar for /WG versions
 (2) Max speed is 1000 rpm for /WG and /PE versions;
 (3) Flow rate and power consumption are proportional to rotation speed

3 MAIN CHARACTERISTICS OF FIXED DISPLACEMENT RADIAL PISTON PUMP TYPE PFR

Installation position	Any position. If the pump is installed in vertical position, it is advisable to install on the outlet pipe a proper valve for air bleeding (consult our technical dept.). They are not self-priming therefore their installation under oil level is recommended. Installation above oil level requires foot valve on inlet line and pump central point located no more than 150 mm above minimum oil level. The shaft of the pump has an eccentric cam which rotates with the shaft generating the stroke of the pistons and thus generating the flow rate. For best functioning a balanced coupling should be provided between the shaft of the motor and the shaft of the pump. See section 10								
Commissioning	PFR pumps can be reversed without changing the flow direction. Therefore both directions of rotation are permitted. It is recommend to start the pump by short impulses, with pump case filled and air bleed plugs unlocked. Pumps type PFR-3 and PFR-5 have 2 air bleeds, normally plugged, ports located near to the P ports. To help filling and air bleeding, it could be advisable to install a vertical pipe connected on the intake line, just before the inlet port flange.								
Loads on the shaft	Axial and radial loads are not allowed on the shaft. The coupling should be sized to absorb the developed peak horsepower.								
Ambient temperature	from -20°C to +70°C								
Fluid	Hydraulic oil as per DIN 51524...535; for other fluids see section 11								
Recommended viscosity	<table border="0"> <tr> <td>max at cold start</td> <td>800 mm²/s</td> </tr> <tr> <td>max at full power during operation</td> <td>100 mm²/s</td> </tr> <tr> <td>min at full power</td> <td>24 mm²/s</td> </tr> <tr> <td></td> <td>10 mm²/s</td> </tr> </table>	max at cold start	800 mm ² /s	max at full power during operation	100 mm ² /s	min at full power	24 mm ² /s		10 mm ² /s
max at cold start	800 mm ² /s								
max at full power during operation	100 mm ² /s								
min at full power	24 mm ² /s								
	10 mm ² /s								
Fluid contamination class	ISO 19/16 (filters at 25 µm value with β ₂₅ ≥ 75 recommended)								
Fluid temperature	-20°C +60°C -20°C +50°C (W/G seals) -20°C +80°C (PE seals)								
Recommended pressure on inlet port	from -0,1 to 1,5 bar for speed up to 1800 rpm								

4 TORQUE VERSUS PRESSURE DIAGRAM

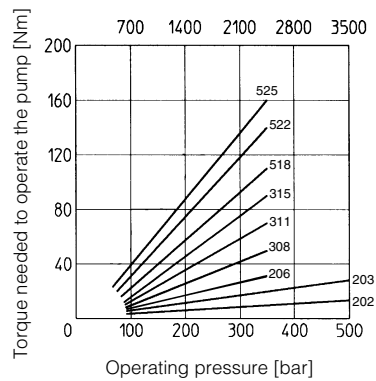

5 NOISE LEVEL

Ambient noise levels measured in compliance with ISO 4412-1 oleohydraulics -Test procedure to define the ambient noise level - Pumps
Shaft speed: 1450 rpm. Mineral oil ISO VG 46 at 50°C.

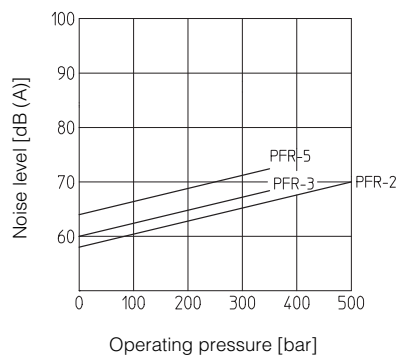

6 LIMIT OF SHAFT TORQUE

Pump model	Maximum driving torque [Nm]	Maximum torque available on the end of the through shaft [Nm]
PFR-2	200	=
PFR-3	600	320
PFR-5	800	320

The values of torque needed to operate the pumps are shown for each type on the "torque versus pressure diagram" at section 4. In multiple pumps the total torque applied to the shaft of the first element (drive shaft) is the sum of the single torque needed for operating each single pump and it is necessary to verify that this total torque applied to the drive shaft is not higher than the values indicated in the table.

7 DIMENSIONS OF SINGLE PUMPS [mm]

PFR-2

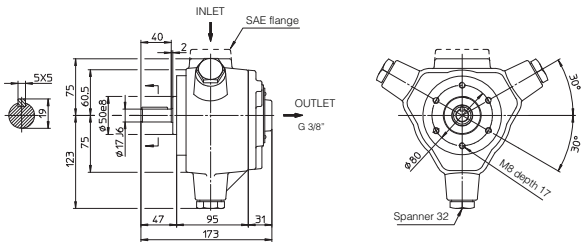

Mass: 12 Kg

PFR-3

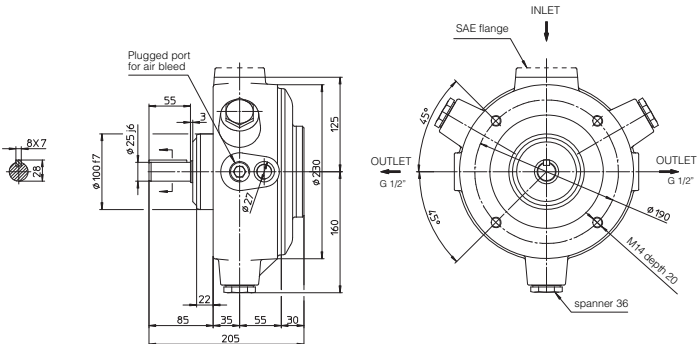

Mass: 31 Kg

PFR-5

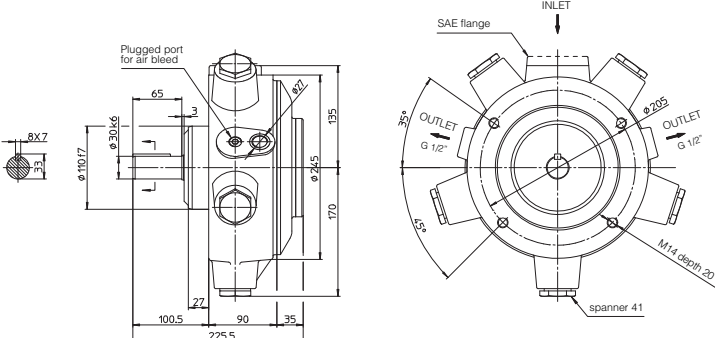

Model	Mass kg
PFR-518	38
PFR-522	
PFR-525	

(•) SAE flanges are supplied with the pump

8 SAE-3000 FLANGES supplied with the pump [mm]

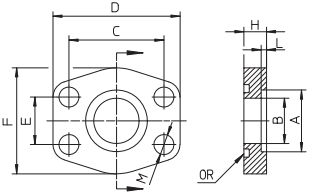

Flanges are supplied with seal and screws M10 class 12.9
Tightening torque = 70 Nm

Pump model	Flange code	A	B	C	D	E	F	H	L	M	OR	Screws
PFR - 2	WFA-25	35,5	29	52,37	70	26,19	55	12	4	ø 11	4131	M10x30
PFR - 3	WFA-32	42,5	34	58,72	79	30,18	68	12	4	ø 11,5	4150	M10x35
PFR - 5												

9 DIMENSIONS OF PUMPS PROVIDED TO BE COUPLED WITH VANE PUMPS [mm]

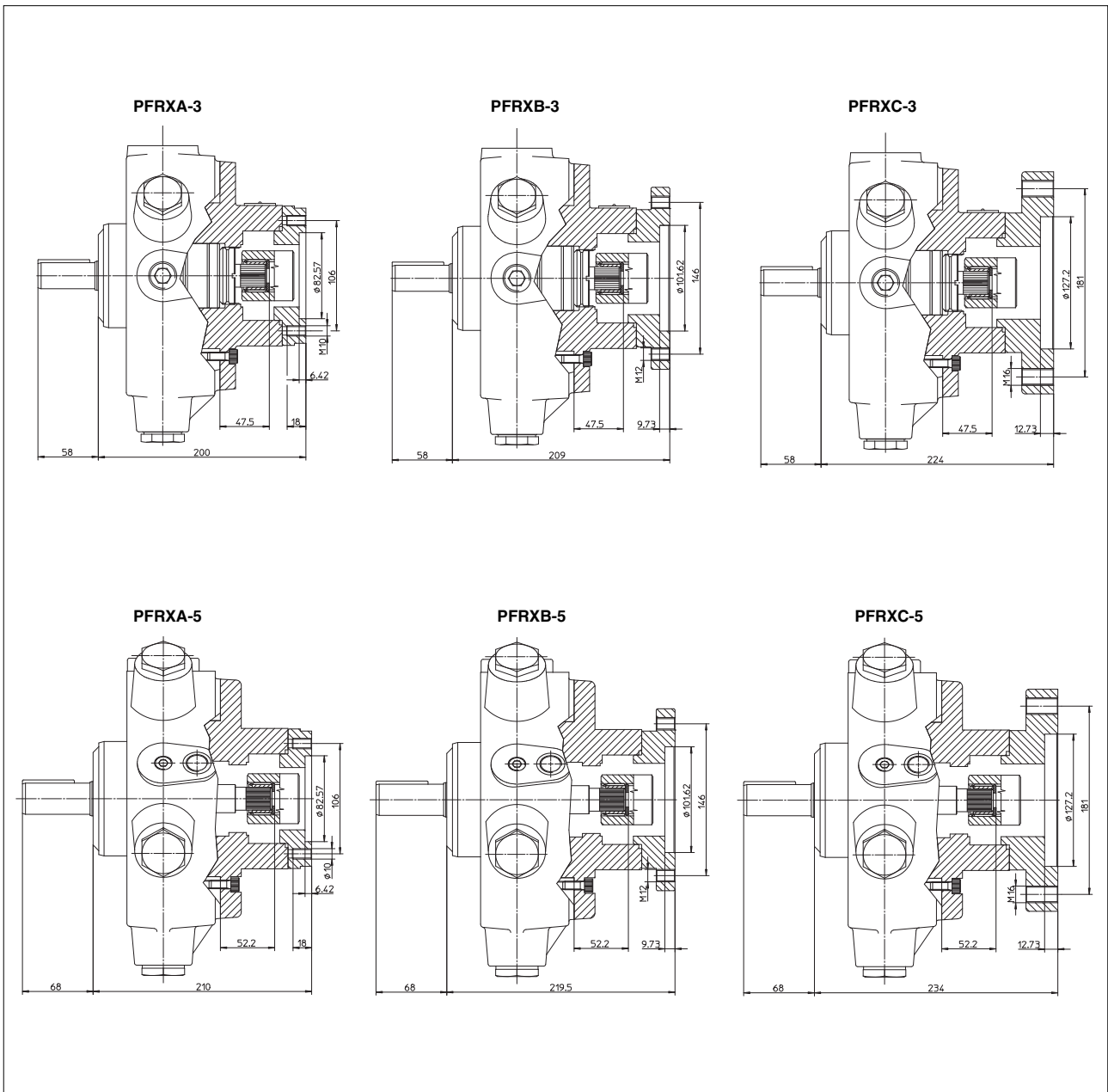

10 BALANCED COUPLING

The balanced couplings permit to minimize the vibrations caused by the unbalanced mass during the pump rotation. The couplings listed in the table, supplied by Atos, must be used together with the relevant bell housing (supplied by Scoda). The table lists the codes of the Atos balanced couplings and the Scoda bell housing, available for the several pumps and for the standardized sizes of the electrical motors.

PUMP MODEL	ELECTRICAL MOTOR	BALANCED COUPLING	BELL HOUSING
PFR-202	UNEL-MEC 100-112	Y-GB-82/02	Y-LS4P2
	UNEL-MEC 132	Y-GB-122/02	Y-LS6P2
PFR-203 e PFR-206	UNEL-MEC 100-112	Y-GB-82/03	Y-LS4P2
	UNEL-MEC 132	Y-GB-122/03	Y-LS6P2
PFR-308	UNEL-MEC 100-112	Y-GB-83/08	Y-LS4P3
	UNEL-MEC 132	Y-GB-123/08	Y-LS6P3
	UNEL-MEC 160	Y-GB-303/08	Y-LS7P3
PFR-311	UNEL-MEC 100-112	Y-GB-83/11	Y-LS4P3
	UNEL-MEC 132	Y-GB-123/11	Y-LS6P3
	UNEL-MEC 160	Y-GB-303/11	Y-LS7P3
PFR-315	UNEL-MEC 100-112	Y-GB-83/15	Y-LS4P3
	UNEL-MEC 132	Y-GB-123/15	Y-LS6P3
	UNEL-MEC 160	Y-GB-303/15	Y-LS7P3
PFR-518	UNEL-MEC 132	Y-GB-125/18	Y-LS6P5
	UNEL-MEC 160	Y-GB-305/18	Y-LS7P5
	UNEL-MEC 180	Y-GB-605/18	
PFR-522	UNEL-MEC 132	Y-GB-125/22	Y-LS6P5
	UNEL-MEC 160	Y-GB-305/22	Y-LS7P5
	UNEL-MEC 180	Y-GB-605/22	
PFR-525	UNEL-MEC 132	Y-GB-125/25	Y-LS6P5
	UNEL-MEC 160	Y-GB-305/25	Y-LS7P5
	UNEL-MEC 180	Y-GB-605/25	